

UF/PNPI HIGH VOLTAGE SYSTEM IN THE LHCb MUON DETECTOR

N.F. Bondar, S.V. Bondarev, N.B. Isaev, O.E. Maev, A.V. Mylnikova,
E.M. Orischin, L.O. Sergeev, S.S. Volkov

1. MUON detector in LHCb

The muon system [1], shown in Fig. 1, consists of five stations (M1–M5) of rectangular shape, placed along the beam axis. Each Muon Station is divided into four regions, R1 to R4 with the distance increasing from the beam axis. The full system comprises 12 pairs of triple GEMs (M1R1), 264 double-gap MultiWire Proportional Chambers (MWPC) in M1/R2–R4 and 1104 four-gap MWPCs in M2–M5.

All the muon stations, including the iron filters, are separated into two halves called A(access)-side and C(cryogenic)-side, which can move on rails away from the beam pipe for maintenance and installation. For M2–M5 stations, two large support structures built from iron beams accommodate the suspensions for the four chamber support walls and have platforms for electronics racks (4 racks on each side) and a gas system (2 racks on a side). The cable chains provide unbreakable connections of all the cables, optic fibers and pipes with the movable sides of the detector. Special racks with patch panels are located near each side of the detector as terminals of the cable chains. Station M1 has an independent support structure.

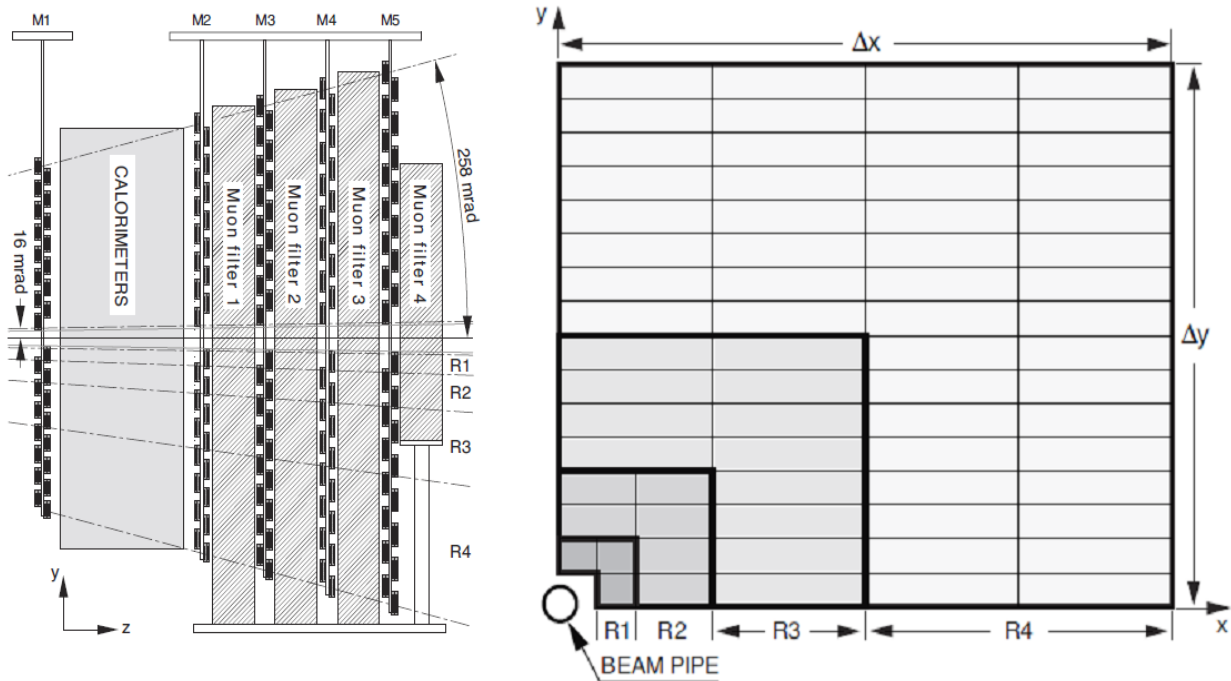

Fig. 1. Left – side view of the muon system. Right – front view of a quadrant of a muon station. Each rectangle represents one chamber, each station contains 276 chambers

2. Selection of a HV system

Due to great variations in technical requirements to HV parameters within the stations and regions in the MUON detector and taking into account the limited budget of LHCb, the choice of a HV system was a really big issue. Finally, the gas gain in MUON is now controlled by three independent HV systems: the INFN HV system was specially developed to control the gas gain in 72 HV channels of GEMs (M1R1), the CAEN system is serving R2–R4 regions in M1 and R1–R2 in M2–M5 – with 1104 channels, and the UF/PNPI HV system has been chosen for R3–R4 in M2–M5 with 3840 channels.

Initially, this multi-channel High Voltage Distribution and Monitoring System (HVDMS) was designed and produced by UF/PNPI collaboration for the End-cap Muon detector of the CMS project, and it met most of the LHCb requirements. To fit the LHCb chambers, special “LHCb-type” HV connectors were installed on the distribution boards [2]. A two stage configuration was selected for the LHCb muon detector.

The total number of HV channels is 3840. Taking into account the granularity of the HV system and the detector configuration we had to produce 4032 HV channels. To minimize initial price of the HV system, the production was divided into two stages. At Stage 1, all the chamber gaps of R3 are fed individually. Some of the gaps of the R4 chambers are connected in parallel in groups of four via the patch panels. The gaps connected in parallel always belong to different chambers to minimize losses of the efficiency. At Stage 2, all the chambers should be fed individually.

This solution allowed us to produce only half of the channels – 2016. Also, we have designed and produced a relatively cheap splitting device called “HV Patch Panel” (HV PP) for other 2016 channels.

At Stage 1, we produced:

- PCI card of the System Interface/Buffer (Host Card) – 6 modules plus 2 spares;
- 8-channel Master Distributor Board (MB) – 8 modules plus 2 spares;
- 36-channel radiation hard Remote Distributor Board (RDB) – 56 modules plus 10 spares;
- 320-channel HV Patch Panel – 8 units.

As a primary HV power supply, the Matsusada AU-5P60-LF was selected – 2 units plus 1 spare. Also, for a low voltage power supply, the WIENER type VEP 6021-LHC was selected – 1 unit.

For Stage 2, we had to produce additional 56 RDB modules and 8 MB modules to replace 8 units of the HV PP.

3. UF/PNPI HV layout in LHCb

The HV system layout is presented in Fig. 2. To follow the LHCb structure, the HV system is also divided into two independent parts, for the A-side and C-side. Each part has a complete set of equipment: a computer with 3 host cards, a Primary HV power supply and an individual crate with 4 Master Distributor boards. The low voltage power supply has 5 output channels. It allows to feed independently Remote Distributors on each side with ± 8 volt power and to supply all the Master Distributors with 12 volts.

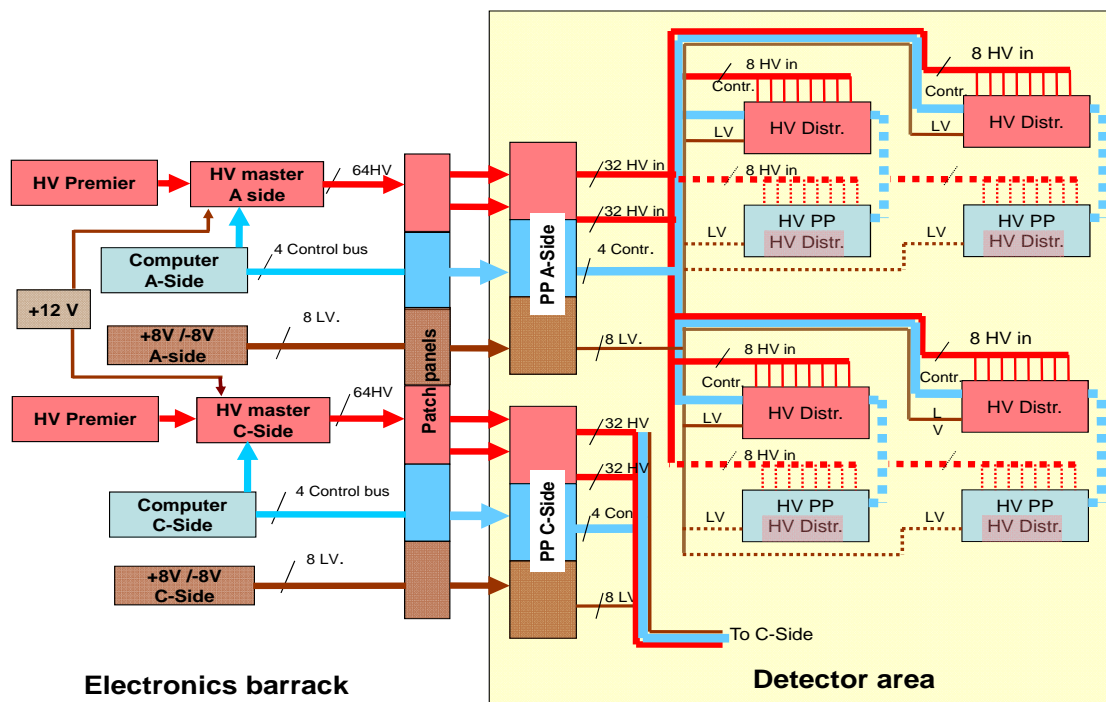

Fig. 2. UF/PNPI HV system layout of the LHCb muon detector. The remote distribution part is presented for the A-side

All the components including 2 computers, 2 Matsusada power supplies, 2 crates with 4 MB in each, and the low voltage WIENER power supply were assembled in one rack. The rack was installed in the electronics barrack away from the detector, so that it was always accessible even during the beam time. The cables for the low and high voltage, the signal cables for the final system layout were placed between the rack and two patch panels in the detector area. All the voltages and control signals were delivered from these patch panels to the Remote Distributors crates with flexible cables. The total length of the cables was more than 100 meters. The voltage drop and the signal cable skew was taken into account.

Since one control line can serve only up to 16 RDB modules, for the maximum number (56) of the RDB modules on each side we had to put 4 control lines per side. Currently, for Stage 1 we are using half of the RDB modules (28 at one side) and only 2 control lines per side.

In Fig. 2, the red boxes “HV Distr.” are the crates with the RDB modules, and the blue boxes “HV PP/HV Distr.” are the HV Patch Panels. These Panels have the same size as the RDB crate, so to implement Stage 2 we should replace these Patch panels with the RDB crates and reconnect some HV cables to chambers and rearrange the control lines. All the signal cables, the HV and power cables are now installed for the final version of the UF/PNPI HV system.

4. Improvement of the system parameters on the base of the operation experience

The first two years of operation were like a burn-in time for the system. There were quite a large number of failures that required a lot of attention, and changes to improve the system reliability and the precision of the specified and measured parameters.

First, it was found that the output voltage in some channels drifts, and biases in several channels were observed in both directions. Therefore, a procedure of calibration of the sensor output voltage was introduced to all channels directly in the detector. The reason for the voltage instability was low reliability of the 1 GigaOhm resistors in the HV divider circuits, which were used in each channel of the voltage stabilizer and also used as sensors of the output voltage. During a shutdown, these resistors were replaced by more reliable resistors in all the RDB and MB modules.

The second problem we faced in Stage 1 was a high level of the output current noise in some channels of the RDB and MB. Sometimes, this noise led to false alerts of the overcurrent protection circuit during ramping up of the output voltage, which impeded severely setting up of the system into the operation mode. The main reason of this excess noise was found to be some instability of the voltage regulators in these channels. The replacement of the 1GigaOhm resistors of the HV dividers improved the noise performance significantly. Also, we tuned the stabilizer parameters in all the RDB channels. Finally, we have reached the resolution of the current sensors for all the RDBs better than one ADC step.

The voltage regulator of the MB has four FETs connected in series. This solution allows to make a 4 kV stabilizer using 1.0 kV transistors. Unfortunately, this circuit is not very stable, in particular, during ramping up the output voltage. By selecting parameters of the transistors, we were able to assemble quite stable voltage regulators for the MB. Unfortunately, these regulators tend to aging, their stability being decreased. Now, there is a new commercially available transistor with the working voltage of 1.5 kV. We have designed a new version of the MB regulator specified for 3 kV with 2 transistors. This regulator is simpler and more stable, and can be used for the LHCb muon chambers since the HV in these chambers is lower than 2.8 kV.

There is a proposal to improve the temperature stability of the current sensors up to 1.5 nA/10 °C. This modification will be implemented in new modules.

One channel of the MB can supply up to 36 gas gaps through the RDB. In the case of a short circuit in any gap or in an RDB channel, all the 36 outputs will be tripped. To keep the maximum efficiency of the muon detector, a special remotely disconnecting fuse is installed in the output of every RDB channel. It allows to disconnect a failed channel during the beam time, when the LHCb cavern is closed for access. Because of large cable lengths and small wire cross sections, this procedure was not reliable enough. To improve it, we have increased the burning voltage up to 60 V.

According to the LHCb specifications, the HV control system must be USB controllable. This work is in progress, a new control system will be implemented during the 2013 shutdown.

5. HV system performance

Since 2009, the HV system is working under option “Stage 1” [3]. The main task of the system is to keep the output voltage within the specified limits to provide a homogeneous and stable gas gain in MWPCs. The system has a very useful feature, which apparently is a great competitive advantage over most commercial HV-systems. It is the ability to control and monitor the precision of the output voltage sensors and to recalibrate them if necessary. The procedure is as follows: we set the HV-transistors to the fully open state and measure the voltage set on the primary power supply with the RDB voltage sensors. To have this option precise, we need properly calibrated primary power supplies, which are always accessible, only two of them being in the system.

This procedure allows us to sustain the output voltage with the precision of ± 5 V (Fig. 3). The system has the current measurements resolution about 1 step of an ADC. The average quantity of faulty channels per year is less than 5 out of 2000. The average quantity of disconnected channels is about 3 per year.

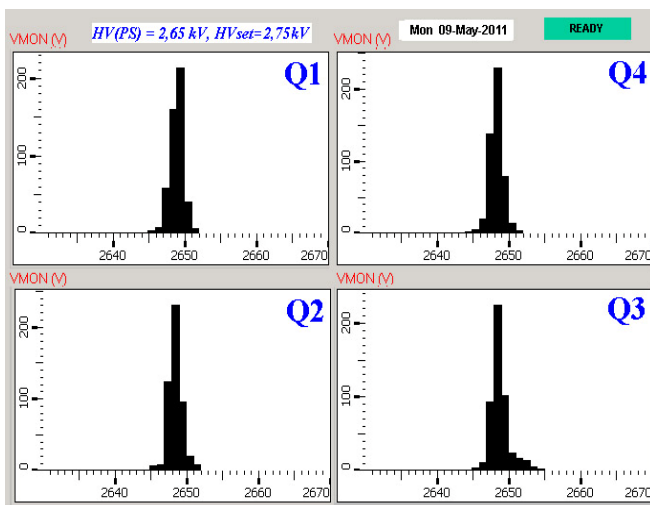

Fig. 3. Typical distribution of the measured voltages at the RDB outputs

After the period of 3 year maintenance and modifications described above, the HV system behaves very stable and reliable. Stage 2 is in progress, and the complete system must be commissioned and put into operation after the long shutdown in 2013–2014.

The authors thank Genakh Mitcelmakher, Alex Madorsky and Victor Barashko for technical support and useful consultations during the period of installation and commissioning of the HV system in the MUON detector.

Referenses

1. The LHCb Detector at the LHC/ LHCb Collaboration 2008, J. Instrum. **3** (2008).
2. S.V. Bondarev, N.B. Isaev, V.I. Lazarev, A.V. Mylnikova, L.O. Sergeev, S.S. Volkov, Multi-Chanel High Voltage Distribution and Monitoring System for LHCb Muon Chambers in *PNPI High Energy Physics Division, Main Scientific Activities 2002–2006*, Gatchina, 2007, p. 335.
3. A.A. Vorobyev *et al.*, Experiment LHCb at the LHC, this issue.