

HISTORY AND PRESENT STATUS OF PNPI SYNCHROCYCLOTRON

N.K.Abrossimov, S.P.Dmitriev, V.A.Eliseev, G.F.Mikheev, G.A.Riabov,
N.N.Chernov

One of the main experimental facilities at PNPI is the synchrocyclotron for acceleration of protons up to 1 GeV kinetic energy. The PNPI synchrocyclotron was designed for a wide program of fundamental research (elementary particle physics, nuclear structure, mechanism of nuclear reactions) as well as for medical and technical applications. The basic requirement to the accelerator was a possibility to provide the beams of various particles with variable energies. A special attention was paid to design the extracted proton beam with relatively high intensity and appropriate time structure, as well as to design a number of secondary beams such as neutron, pion, and muon beams. The measures were undertaken to reduce the radiation background in the experimental halls. The design, construction, and start up of the 1 GeV synchrocyclotron were performed by a joined team of Efremov Institute ¹ and LPTI ². The accelerator equipment was mainly manufactured by the Leningrad plant "Electrosila", an extensive upgrade program of the accelerator was carried out by PNPI.

Accelerator project development

The conceptual design of the main synchrocyclotron systems had been done at Efremov Institute with LPTI participation according to the technical specifications elaborated at LPTI. Coordinators and design group leaders from Efremov Institute were E.G.Komar, I.F.Malyshev, B.V.Rozhdestvensky, I.M.Roife, E.V.Seredenko, A.T.Chestnokov, N.A.Monoszon, I.V.Gusev, and V.I.Peregud. The main participants of the synchrocyclotron design from LPTI were D.G.Alhazov, D.M.Kaminker, N.K.Abrossimov, N.N.Chernov, A.V.Kulikov, G.A.Riabov, V.A.Eliseev, S.P.Dmitriev, G.F.Mikheev. Later, Yu.T.Mironov and V.I.Shalmanov joined this team. As the result the magnet and the vacuum chamber had been elaborated, the conceptual design and the technical project of the high frequency system have been developed, the ion source and the extraction system had been worked out. A set of non-standard equipment and auxiliary systems (such as the vacuum pumping system of unique productivity, the power supply system for the main magnet and for the magnets of the beam transport lines, the water cooling system, ventilation, dipoles and quadrupoles for the beam transport system) had been also designed.

Construction of the world's largest synchrocyclotron magnet with the pole diameter of 6.85 meters and with 1.9 T magnetic field appeared to be a complicated technical problem. Optimization of the magnetic circuit, coils and magnet configuration allowed to decrease the magnet weight and power consumption. The basic parameters of the synchrocyclotron magnet are presented in Table 1.

¹D.V.Efremov Scientific Research Institute of Electrophysical Apparatus

²A.F.Ioffe Leningrad Physical-Technical Institute

Table 1
Basic parameters of the synchrocyclotron magnet

Pole diameter	6.85 m
Gap without shims	0.5 m
Field in the centre of air gap	1.9 T
Maximum field in the steel	up to 2.2 T
Number of turns in the coil	264 (22×12)
Conductor filling factor for the coil	52 %
Conductor of the main coil	Al 83×83 mm ² / 30 mm
Resistance of the main coil	0.038 Ω
Inductivity of the main coil	5 H
Current in the main coil	4600 A
Power supply voltage	200 V
Number of turns in the additional coil	48 (2×24)
Current in the additional coil	600 A
Stability of the power supply current	10 ⁻⁵
Weight of iron	7800 t
Weight of the main coil	120 t
Consumption of cooling water	30 m ³ /h
Overall dimensions	16.5×7.8×10 m ³

The most serious problem in the synchrocyclotron design was development of the high frequency accelerating system with the frequency ratio of 2.3 corresponding to the final energy of 1 GeV. It seems that the 1 GeV energy is the ultimate limit for this kind of accelerators because of the problems in implementation of the HF system with such a wide frequency range. The required frequency range was realized by using a new and rather sophisticated design of the rotating capacitor with the capacity ratio equal to 40. This was achieved by inserting an additional stator blade set and by introducing in the frequency variator scheme a system of parallel and series inductivities. The basic parameters of the high frequency system are presented in Table 2. Difficult problems were met in the design of the 35 m³ vacuum chamber with the operating pressure of $2 \cdot 10^{-6}$ mm Hg and in the design of other systems such as the ion source, the beam extraction electrodes, the internal targets, the vacuum pump, and water cooling.

The civil engineering of the synchrocyclotron building with technology systems was performed at LPI ³. The design of electric equipment was done at Efremov Institute and at SPI "Tyazhprom–elektroproekt" ⁴. The construction of the synchrocyclotron was started in 1959. In 1964 the installation of the main magnet and its power supply system was completed. Then the comprehensive tests and setting-up works were started.

³Leningrad Project Institute

⁴State Project Institute "Tyazhprom–elektroproekt"

Table 2
Basic parameters of the synchrocyclotron
high frequency system

Frequency range of the accelerating voltage	$f_i = 30.2$ MHz $f_f = 12.9$ MHz
Operating range of frequencies	$f_i = 28.88$ MHz $f_f = 13.18$ MHz
Macro duty cycle	0.5
Amplitude of the accelerating voltage	8 kV
Repetition rate	50 Hz
Power consumption	150 kW

Magnetic field shimming, renovation of the high frequency system, reconstruction of the ion source and extraction system, putting into operation and attainment of the project parameters

PNPI was responsible for formulation of the technical and physical requirements to the accelerator, for comprehensive testing of all its systems, and for putting it into operation. In this context the main problems were: to determine the tolerances of the magnetic field of the synchrocyclotron, to perform magnetic measurements, shimming and correction of the magnetic field, to obtain proper accelerating voltage within the whole frequency range, to construct the beam extraction and the beam transport systems to deliver protons into the experimental hall.

The magnetic measurements and field shimming were carried out during 1965–66. The measurements were performed with a special automatic system. The computer controlled system consisted of a set of nuclear magnetic resonance (NMR) and Hall field probes and a scanning machine for positioning the field probes at a given point of the magnet gap. The relative accuracy of the magnetic field measurements was $5 \cdot 10^{-5}$. To find the position of the median plane, a method was developed to measure the small radial magnetic field component in the presence of thousand times larger vertical component by using a Hall probe oriented along the direction of the gravity force (so called "Russian pendulum"). The proper distribution of the magnetic field in the radial direction, the correction of the azimuthal inhomogeneity, and the correct positioning of the median plane were provided by attaching the ring-shaped shims on the up and down pole faces [1]. The main parameters of the synchrocyclotron magnetic field are presented in Table 3.

The first start-up of the accelerator took place in November 1967. The proton beam was accelerated up to the energy of 750 MeV. The project energy of 1 GeV was not achieved because of some problems with the high frequency accelerating system [2].

During 1968–69 the first stage of the synchrocyclotron upgrading was carried out by the PNPI accelerator staff. As a result, the project energy of 1 GeV was obtained and a new high efficiency extraction system was designed and implemented.

Table 3
Basic parameters of the synchrocyclotron
magnetic field

Magnetic field in the centre	1.9 T
Extraction radius	3.167 m
Field at extraction radius	1.786 T
Magnetic field fall-off	6 %
Field index at the extraction radius	< 0.1
Pole utilization factor	0.924
Amplitude of the first harmonic of the magnetic field	$< 2 \cdot 10^{-4}$
Average displacement of the median plane	± 5 mm
K value in the central region	~ 4

The rotating capacitor design had been reviewed to obtain the necessary capacity coverage. To increase the ultimate capacity of the variator, an additional inductivity for the stator blade set had been introduced. To cut down the voltage on the variator rotor, the rotor-ground capacity had been increased by increasing capacity of the grounding blade set and the coaxial cylinder capacitors. Instead of the feed back system developed at Efremov Institute in which the additional rotating capacitor was used, a new static (without moving parts) system of coupling and feed back coaxial feeders had been designed and realized. This system provided constant voltage transformation from the generator anode to the accelerating gap within the full frequency range, as well as reliable suppression of the parasitic transversal oscillations.

The extraction system developed by Efremov Institute was redesigned on the base of the extraction efficiency analysis. The proposed non-linear regenerative extraction system consisted of a regenerator and a special magnetic channel. Extensive computer calculations of the beam trajectories in the real magnetic field of the synchrocyclotron were carried out, and the extraction efficiency dependence on the beam quality before extraction and on the extraction system parameters were investigated. On the base of the calculations the effective vertical aperture of the regenerator and the magnetic channel had been significantly increased. Also, the focusing gradients in the magnetic channel had been introduced and optimized. During implementation of the new extraction system, special attention was paid to the field shimming to cancel the channel influence on the magnetic field in the region of particle acceleration. As a result, after careful tuning of all the accelerator systems, the highest for synchrocyclotron extraction efficiency of 30% was achieved [3].

Simultaneously with the design of the extraction system, the proton beam transport system was developed. The high extraction efficiency has made it possible to abandon the internal target for secondary beams production and to use an external target.

Instead of the ion source with a hot cathode which required frequent replacement of the filament, a cold cathode ion source of the Penning type developed at JINR⁵ (Dubna) was used.

From April 1970 the synchrocyclotron has been put into routine operation with running time of about 5000 hours per year [4].

⁵Joint Institute for Nuclear Researches

Synchrocyclotron upgrade

An extensive synchrocyclotron upgrade program was initiated just after its start up. The main goals were to increase the intensity of the beams, to improve the beam quality and the time structure, to construct new beam lines, to raise the reliability and the operation efficiency of the accelerator.

In 1972 a new beam stretching system was developed which allowed to increase the macro-duty factor of the extracted beam from 1.4% up to 50%. An additional C-shape electrode is placed in the region of the final radii of the acceleration. After the beam bunch is accelerated up to the final energy, the main accelerating system is switched off and the new system slowly reaccelerates protons during the fly-back time of the frequency variator ($\sim 50\%$ of the repetition period). The high capture efficiency of the stretching system was provided by the frequency and phase lock between the main and the C-electrode generators. The implementation of the beam stretcher has opened a new horizon for electronics experiments [5].

In 1973 a pulsed deflector was installed for one turn deflection of the proton beam onto the internal neutron-production target placed outside the median plane. The C-electrode with disconnected up and down plates was used as the deflector. By using this deflector it was possible to generate a pulsed beam of neutrons in the energy range from 10^{-2} eV up to 10 MeV with the pulse duration of 7–30 ns. Thereafter time-of-flight neutron spectrometer (GNEIS ⁶) had been built up with a 40 m flight length [6].

In 1974 a new rotating capacitor designed and manufactured at PNPI was installed at the synchrocyclotron. It allowed to increase the amplitude of the accelerating voltage and to optimize the frequency-time dependence. As a result, the internal beam intensity was increased up to $0.7 \mu\text{A}$ and the extracted beam intensity – up to $1.3 \cdot 10^{12}$ proton/s. But the main effect was an improved reliability and an essential decrease of the maintenance time. After installation of this variator, the time for physical experiments reached 6000 hours per year.

In 1977 an electrostatic focusing system for the central region of the synchrocyclotron was designed. The intensity of the internal beam was increased up to $3.5 \mu\text{A}$ and the intensity of the external beam reached $1 \mu\text{A}$ [7].

During 1974–80 several new beam lines had been constructed: a proton beam for the proton therapy, a combined $\pi - \mu$ channel, the polarized proton and high energy neutron beams. This was an essential improvement of the experimental facility.

In 1975 a medical application of the 1 GeV proton beam for treatment of some brain diseases, in particular pituitary adenomas and arteriovenous malformation, was started. Usually proton therapy centres exploit the 70–200 MeV proton beams. The protons stop in the patient body, and the needed dose distribution is formed with the use of the Bragg peak. At the PNPI synchrocyclotron, a narrow (3–5 mm) 1 GeV proton beam traverses the patient body without stopping. The necessary dose distribution with very sharp edges is shaped by using a two-orthogonal-axis isocentric rotation technique developed by the collaboration of PNPI and CRIRR ⁷. The main advantages of this method are a very small spot with high dose up to 120–180 Gy and a sharp dose drop outside the irradiation area. By now about 1000 patients have been treated at the PNPI synchrocyclotron [8].

In 1980 a new muon channel was constructed with an external meson-production target that made it possible to generate high intensity beams of low energy pions. The channel comprises

⁶Generator of Neutrons on the Synchrocyclotron

⁷Central Research Institute of Roentgenology and Radiology of the Ministry of Public Health

the entrance and exit analyzers and the decay path with 20 quadrupole lenses. The construction of the muon channel at the PNPI synchrocyclotron opened possibilities for investigation of the muon-catalyzed fusion, as well as for solid state experiments using the spin-rotation method (μ SR).

During 1980–95 the program of improvement of the PNPI synchrocyclotron was continued. The main efforts were directed on modernization of the beam transport lines, on the beam diagnostic and control. Objectives of this program were: transportation of the proton beam in vacuum, design of new profilometers to measure the beam shape, subsequent data processing and the profile display by the computer. Some new elements for the beam line were introduced: computer controlled vacuum collimators, small magnets-correctors, new magnetic quadrupoles, a remote controlled target station with fine tuning of the meson-production target position in the direction transversal to the beam, geodesic marks for transversal and longitudinal control of the magnetic elements position along the beam line, computer control of the currents in the magnetic elements and also the computer controlled beam transportation in the accelerator hall. The beam line of 60 m length for the IRIS ⁸ laboratory was reconstructed to reach the transition efficiency of 90%. The initial proton therapy beam line was also reconstructed. A supplementary proton beam of low intensity ($\sim 10^{10} \text{ s}^{-1}$) operated simultaneously with the main beam was extracted from the accelerator chamber. This beam was formed of the particles which were lost in the acceleration chamber during the process of the main proton beam extraction. One could mention also a low intensity test beam for calibration of experimental equipment and a special beam for radiation material tests with the possibility to vary the diameter of the irradiated area from 1 cm up to 25 cm with the dose nonuniformity less than 5% and with the neutron contamination less than 1%.

An important feature of the synchrocyclotron beam is a very small energy spread of the internal proton beam defined by the separatrix of the synchrotron oscillations in the contrast to the large overall energy spread of the extracted proton beam. However, the registration of the beam extraction time in the duration of the macro-pulse provides an effective "monochromatization" of the extracted beam with the energy spread $\Delta E/E = 10^{-3}$. This method was successfully used in the proton-nuclei scattering experiments.

Simultaneously with the synchrocyclotron upgrade, the experimental area was also expanded and improved. Special buildings for the laboratory of short-lived isotopes, for the proton therapy, for the computer centre, for the neutron time-of-flight spectrometer had been constructed and equipped (see Fig. 1).

The list of references on the construction and modernization of the synchrocyclotron includes 62 publications and 9 patents.

⁸Investigation of Radioactive Isotopes on Synchrocyclotron

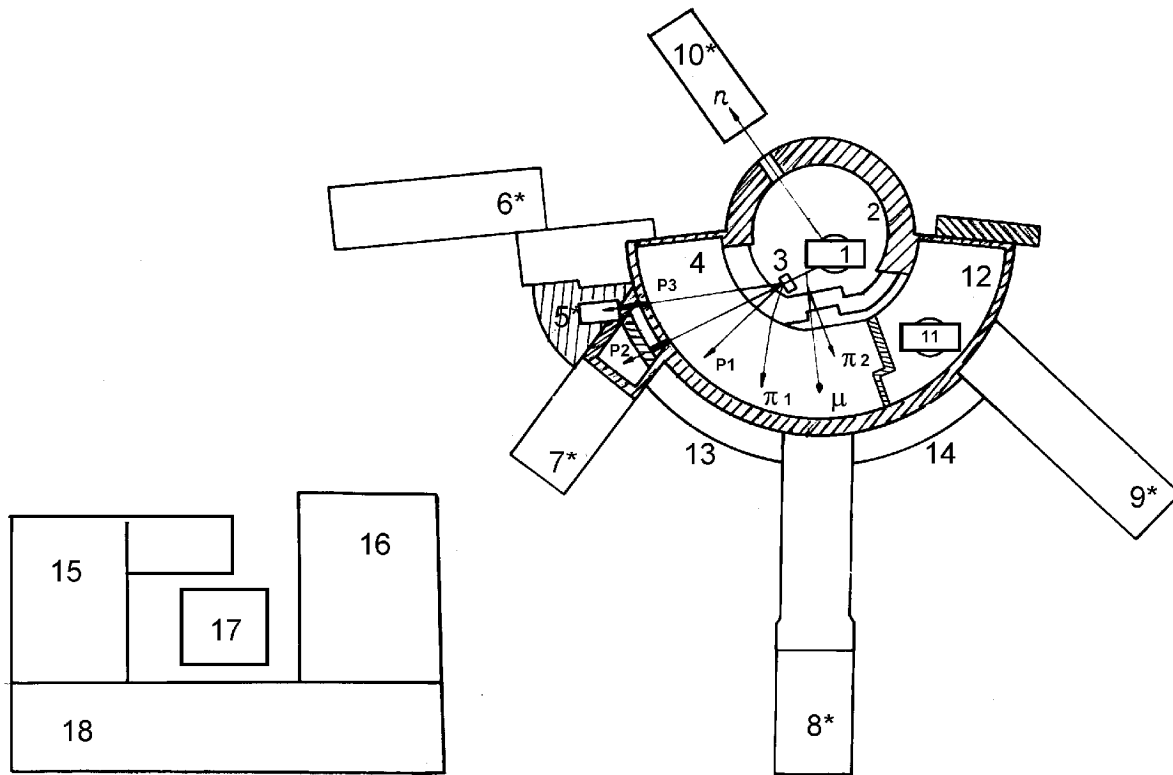

Fig. 1. General view of the synchrocyclotron complex and beam lines. The blocks which were built after the synchrocyclotron start up are marked with *. 1 – the synchrocyclotron; 2 – the main hall; 3 – the beam distributing magnet SP-40; 4 – the experimental hall; 5 – the trap-damper of the proton beam; 6 – IRIS; 7 – the medical facility; 8 – the block of technical maintenance; 9 – the computer centre; 10 – GNEIS; 11 – the isochronous cyclotron under construction; 12 – the cyclotron hall; 13, 14 – the counting rooms; 15 – the equipment test hall; 16 – the power supply hall; 17 – the electrical power supply station; 18 – the administrative block and the synchrocyclotron control room.

Present status of the PNPI synchrocyclotron.

The general view of the synchrocyclotron experimental area and the beam lines are shown in Fig. 1. The layout of the main synchrocyclotron systems is depicted in Fig. 2. The synchrocyclotron is located in a round hall of 32 m in diameter. The experimental hall of a half-ring shape (25 m in width) is separated from the accelerator hall by a 8 m thick wall made of heavy concrete. The collimators in the concrete wall allow to transport beams into the experimental hall.

The extracted proton beam transport line and the channel of the secondary π and μ mesons are depicted in Fig. 3. When operating in the proton mode, the extracted beam is transported by the transport line through the accelerator hall and then it is bent by the magnet SP-40 to pass through one of the collimators to an experimental setup. The beam for the proton therapy is transported by the beam line P2 (see Fig. 3). The proton therapy is carried out in a special building. The high resolution magnetic spectrometer had been constructed in the same beam line P2. The beam line P3 provides the proton beam to the IRIS laboratory where short-lived isotopes are investigated with the mass-separator and the laser technique.

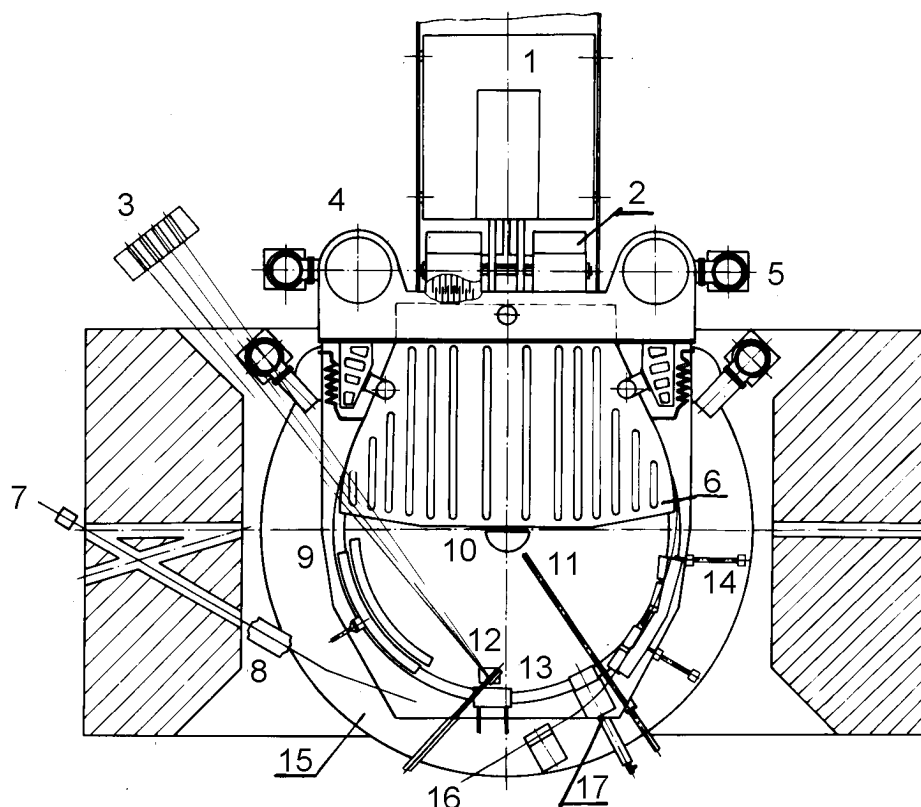

Fig. 2. Layout of the main systems of the PNPI synchrocyclotron. 1 – HF generator; 2 – the frequency variators; 3 – the collimator of the impulse neutron beam (GNEIS); 4 – high vacuum pumps VA-40-2; 5 – high vacuum pumps VA-8-4; 6 – the dee-electrode; 7 – the direction of the second proton beam extraction; 8 – the magnet-corrector; 9 – the C-electrode; 10 – the ion source and the focusing electrode; 11 – the probe; 12 – the target and the neutron moderator of GNEIS; 13 – the additional magnet channel; 14 – the main magnet channel; 15 – the electromagnet coil; 16 – the direction of the main beam extraction; 17 – the regenerator.

The main parameters of the proton beams are presented in Table 4.

One meson-production target installed in the accelerator hall is used by the three meson channels, so these channels (π_1 , π_2 or μ) can be operated simultaneously. The basic parameters of the secondary beams are presented in Table 5. The layout of the neutron-production internal target in the accelerator chamber, as well as the directions of the neutron beams are shown in Fig. 2. The parameters of the neutron beams are presented in Table 6.

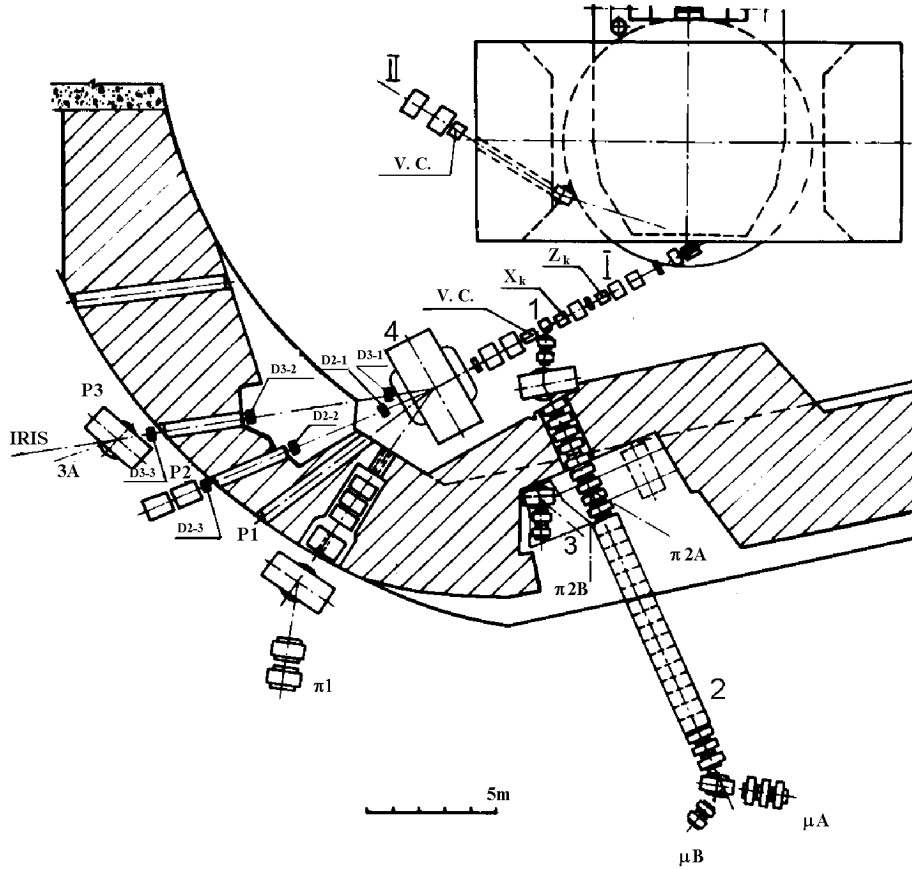

Fig. 3. The beam lines of the PNPI synchrocyclotron.

I – the main proton beam ($6 \cdot 10^{12} \text{ s}^{-1}$); II – the supplementary proton beam (10^{10} s^{-1}).
 1 – the meson-production target; 2 – the μ meson channel; 3 – the platform with the second magnet of the low energy pion channel; 4 – the bending magnet SP-40; P1, P2, P3 – proton beam lines; D2-1, D2-2, D2-3, D3-1, D3-2, D3-3 – movable beam dampers; $\pi 1$ – the high energy π meson channel; $\pi 2A$, $\pi 2B$ – directions of low energy meson beams; μA , μB – directions of μ meson beams; Z_k – the vertical magnet-corrector; X_k – the horizontal magnet-corrector; V.C. – the vacuum collimators.

Table 4
Proton beams

Particles	Energy, MeV	$\Delta E/E$, %	Intensity, part./s	Beam line	Notes
p	1000	1	$6 \cdot 10^{12}$	P1, P2, P3	Main beam
p	1000	1	10^8	P2	Medical beam
p	1000	0.1	10^{10}	P2	Monochromatic beam
p	1000	1	10^{10}		Supplementary beam

Table 5
Secondary particle beams

Particles	Momentum, MeV/c	$\Delta P/P$, %	Intensity, part./s	Beam line	Notes
π^+ π^-	450 450	6 6	10^6 $3 \cdot 10^5$	$\pi 1$	Achromatic mode
π^- π^+ μ^+	250 250 29	2.5–12 2.5–12 12	$10^5 - 5 \cdot 10^6$ $3 \cdot 10^5 - 10^7$ $3 \cdot 10^4$	$\pi 2$	Achromatic mode. "Surface" mesons
μ^- μ^+	160 170	10 10	$9 \cdot 10^4$ $3 \cdot 10^5$	μ -channel	Separated beams

Table 6
Neutron beams

Energy	Intensity, part./s	Pulse duration, nc	Frequency, Hz
10^{-2} eV – 10 MeV	$3 \cdot 10^{14}$	10	50

After 25 years of operation, the PNPI synchrocyclotron continues to be one of the most active facilities in the intermediate energy region [9]. The synchrocyclotron is still effective in several aspects of nuclear physics study due to the optimal proton energy (1 GeV), the small energy spread and good time structure of the beam. The laser- and mass-spectroscopy laboratory IRIS is among the leading laboratories in investigation of the isotopes far from the stability region. The neutron time-of-flight spectrometer GNEIS also gives some unique possibilities for the neutron spectroscopy due to its very high energy resolution. A number of distinguished physical results were obtained at the synchrocyclotron:

- Investigation of the elastic and quasi-elastic proton scattering on nuclei provided the most precise data on the nucleons spatial distribution in nuclei as well as the characteristics of the deepest nuclear shells.
- More than 60 new proton-rich isotopes were investigated in the region stretched up to the border of nuclear stability.
- Systematic study of πp and pp scattering resulted in the unique phase shift analyses up to 600 MeV for πp and up to 1 GeV for pp elastic scattering.
- The experiments on small angle scattering of hadrons allowed to probe one of the most fundamental theorems in the elementary particles physics-dispersion relations.
- The muon catalyzed dd and dt fusion reactions were studied and the main parameters of these reactions have been determined.
- The most precise measurements of the π -meson mass and lifetime were performed.
- The subthreshold production of K^+ mesons was investigated on the highest level of sensitivity.

At present the basic investigations at the synchrocyclotron are as follows:

- Investigation of the muon catalyzed fusion.
- Study of the $(p, 2p)$ reactions on nuclei.
- Investigation of the η meson production.
- Nuclear spectroscopy of the nuclei far from the stability region.
- Investigation of magnetic properties of alloys with the μ SR method.

Along with the basic research, a program of applied physics is in progress. Among the most significant items of this program are:

- Proton therapy.
- Radiation studies of materials and components.
- Tests of the equipment designed at PNPI for international high energy experiments.

In the future the applied physics program is planned to be extended due to construction of a cyclotron for acceleration of H^- ions up to the energy of 80 MeV with the beam intensity of 100 μA [10]. The construction of the cyclotron is in progress.

References

- [1] *V.A.Eliseev, G.A.Riabov, I.I.Tkach.* // Sov. Phys. – Tech. Phys., 1972. V.16. P.1415.
- [2] *N.K.Abrossimov, D.G.Alkhazov, S.P.Dmitriev, V.A. Eliseev, D.M.Kaminker, A.V.Kulikov, Yu.T.Mironov, G.F.Mikheev, G.A.Riabov, N.N.Chernov, V.I.Shalmanov, E.G.Komar, I.F.Malyshv, N.A.Monoszon, V.I.Peregud, B.V. Rozhdestvenskii, I.M.Roife, E.V.Secredenka.* // Proc. the 7th Int. Conference on High-Energy Charged-Particle Accelerators, Yerevan, 1970. V.1. P.317 (in Russian).
- [3] *N.K.Abrossimov, V.A.Volchenkov, V.A.Eliseev, G.A.Riabov, N.N.Chernov.* // Nucl. Instr. Meth., 1975. V.126. P.221.
- [4] *N.K.Abrossimov, D.G.Alkhazov, S.P.Dmitriev, V.A. Eliseev, D.M.Kaminker, A.V.Kulikov, Yu.T.Mironov, G.F.Mikheev, G.A.Riabov, N.N.Chernov, V.I.Shalmanov, E.G.Komar, I.F.Malyshv, N.A.Monoszon, V.I.Peregud, B.V. Rozhdestvenskii, I.M.Roife, E.V.Secredenka.* // Sov. Phys.–Tech. Phys., 1972. V.16. P.1399.
- [5] *N.K.Abrossimov, S.P.Dmitriev, O.G.Kotov, A.V.Kulikov, G.F.Mikheev, N.N.Chernov.* // Proc. the 3th All-Union Conference on Charged Particle Accelerators, Moscow, 1972. V.2. P.94 (in Russian).
- [6] *N.K.Abrossimov, G.Z.Borukhovich, A.B.Laptev, V.V.Marchenkov, G.A.Petrov, O.A.Shcherbakov, Yu.V.Tuboltsev, V.I.Yurchenko.* // Nucl. Instr. Meth., 1985. V.A242. P.121.
- [7] *N.K.Abrossimov, V.V.Astashin, S.P.Dmitriev, O.G.Kotov, A.V.Kulikov, G.F.Mikheev, A.S.Pokrovskii, G.A.Riabov.* // Proc. the 6th All-Union Conference on Charged Particle Accelerators, Dubna, 1979. V.1. P.277 (in Russian).
- [8] *N.K.Abrossimov, A.N.Vorobyov, V.A.Eliseev et al.* // Med. radiol., Meditsina, 1987. No 8. P.10 (in Russian).
- [9] *N.K.Abrossimov, S.P.Dmitriev, V.A.Eliseev, E.M.Ivanov, Yu.T.Mironov, G.F.Mikheev, G.A.Riabov.* // PNPI Research Report 1993 – 1995, Gatchina, 1996. P.262.
- [10] *N.K.Abrossimov, S.A.Artamonov, P.V.Bogdanov, V.A.Volchenkov, A.A.Vorobyov, S.P.Dmitriev, V.A.Eliseev, B.D.Ershov, V.S.Kuligin, Yu.T.Mironov, G.F.Mikheev, V.N.Moshkin, V.G.Mudrolyubov, A.S.Pokrovskii, G.A.Riabov, V.A.Smolina, G.L.Sokolov, Yu.I.Stogov, A.P.Strokach, V.P.Fominenko, P.V.Chervjakov.* // Proc. the 13th Int. Conference on Cyclotrons and their Applications, 6 – 10 July 1992, Vancouver, Canada. P.58.

1. ELEMENTARY PARTICLE PHYSICS

